

AV23 Solar Obstruction Light

Typical Applications

- Solar Obstruction Light (LIOL A)

Major Benefits

- 5.4km visible range (flashing)
- Integrated solar/battery system
- 12watt solar module
- 7.5Ah SLA battery
- ICAO Approved AV23 Solar Obstruction Light (LIOL A)
- Ultra-high intensity LEDs (no changing globes ever)

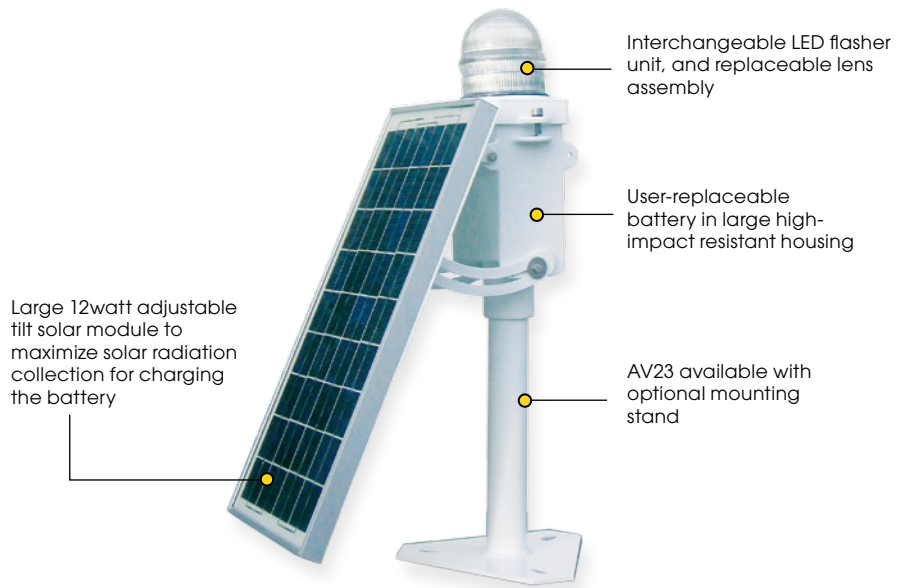

The AV23 is a low intensity solar-powered obstruction light designed to offer users years of maintenance-free operation. The unit is completely self-contained and incorporates a large 12watt solar module, 7.5Ah battery, LED light source and advanced driving circuitry.

During daylight hours the solar module will charge the battery through an advanced switch-mode regulator incorporated into the flasher unit. The lantern will automatically begin operation at dusk – once the ambient light threshold drops sufficiently.

The light is built from heavy-duty cast aluminum - subject to 7-stage powder-coating, and offers users enormous impact and weather resistance.

This completely self-contained unit with integrated solar module and battery system saves users considerably in power, cabling and on-going maintenance associated with traditional incandescent systems.

The AV23 has been independently tested to be in accordance with the requirements of the photometric and colourmetric specifications for a Low Intensity Type A Obstacle Light listed in table 6-3 of ICAO Annex 14 Volume 1, 'Aerodrome Design and Operations', Fourth Edition July 2004.

With minimal access for maintenance, stadium operators in Cyprus now enjoy hassle-free operation of AV23 units, installed as solar obstruction lights.

Sports Stadium Installations, Cyprus



This equipment meets the requirements of a Low Intensity Type A Obstruction Light, ICAO Annex 14 volume 1, "Aerodrome Design and Operations", Forth Edition July 2004.

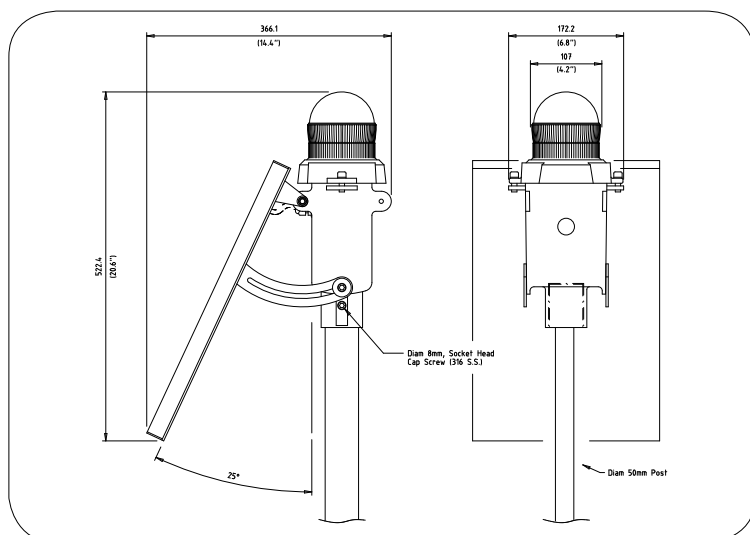

SPECIFICATIONS •

Light Characteristics

Light Source	20 ultra-high intensity LEDs
Available Colours	Red (other colours available)
Peak Intensity (cd)	>25 flashing, >10 fixed-on
Visible Range (nm)	>3 flashing, >2 fixed-on
Horizontal Output (degrees)	360
Vertical Divergence (degrees)	0 to +10
Reflector Type	Omnidirectional 360° LED Reflector (US Pat. No. 6,667,582. AU Pat. No. 778,918)
Available Flash Characteristics	>250 including fixed-on (user-adjustable)
Intensity Adjustments	Adjustable in 25% increments
LED Life Expectancy (hours)	>100,000

Electrical Characteristics

Current Draw (mA)	180
Circuit Protection	Integrated
Operating Voltage (v)	12
Autonomy (days)	>20 (14 hour darkness, 12.5% duty cycle)
Temperature Range	-40 to 80 °C

Solar Characteristics

Solar Module Type	Multicrystalline
Output (watts)	12
Solar Module Efficiency (%)	14
Charging Regulation	Microprocessor controlled

Power Supply

Battery Type	SLA (Sealed Lead Acid)
Battery Capacity (Ah)	7.5
Nominal Voltage (v)	12

Physical Characteristics

Body Material	7-stage powder-coated aluminum
Lens Material	LEXAN® Polycarbonate – UV stabilized
Lens Diameter (mm/inches)	107 / 4 1/4
Lens Design	External optics with interior flute design
Mounting	50mm OD pole
Height (mm/inches)	522 / 20 2/3
Width (mm/inches)	366 / 14 3/8
Mass (kg/lbs)	7 / 15 3/8
Product Life Expectancy	Up to 12 years

Certifications

CE	EN61000-6-3:1997. EN61000-6-1:1997
Quality Assurance	ISO9001:2000

Intellectual Property

Patents	US Pat. No. 6,667,582. AU Pat. No. 778,918
Trademarks	AVLITE® is a registered trademark of Avlite Systems

Warranty

Full 3 year warranty

Options Available

- Mounting pole
- Other LED colours to suit different applications
- IR

CE

• Specifications subject to change or variation without notice